



## 10W DC-HVDC CONVERTER

## 200Vdc to 4kVdc & Dual Output



The K10 Series is a 10 Watt Isolated high voltage DC/DC converter that offers a positive or negative & dual high voltage output directly proportional to the input voltage. This low profile, low-cost unit provides low output ripple, EMI/RFI, and conducted emissions with outputs extending from 200 Vdc through 4000 Vdc while having only a .7 volt turn-on voltage. The K10 Series comes standard with Over-Temperature and Over-Voltage supervisory circuits that automatically shutdown the converter while providing a latching fault signal alerting the user that a fault has occurred, ensuring maximum reliability in the field. Remote on/off and continuous short circuit protection are standard.

### FEATURES

- ▶ **Customer Selects Output Voltage**
- ▶ Single Outputs to + or - 4000 Vdc
- ▶ Dual Outputs to +/- 2000 Vdc
- ▶ Low Turn-on Voltage <0.7Vdc
- ▶ Ultra Low Profile 0.5"
- ▶ Over-Temperature Monitoring
- ▶ Over-Voltage Monitoring
- ▶ Auto Fault shutdown
- ▶ Latching Fault Signal
- ▶ TTL compatible on/off
- ▶ No min. load or reduction of input required
- ▶ High EFF. and internal thermal management
- ▶ Low noise and input / output leakage
- ▶ Arc and short circuit protection

### TYPICAL APPLICATIONS

- ▶ Mass Spectrometry
- ▶ Electrostatic Chucks
- ▶ Electrophoresis
- ▶ Capacitor Charging
- ▶ Particle Counter
- ▶ Isolation Testing
- ▶ Medical Laser Treatment

*The appearance of products, including safety agency certifications pictured on labels, may change depending on the date manufactured. Specifications are subject to change without notice.*



## SPECIFICATIONS

ELECTRICAL	
Input Voltage Ranges	0Vdc to 12Vdc 0Vdc to 15Vdc 0Vdc to 24Vdc 0Vdc to 28Vdc
Input Current	< 1.5A
Output Voltage (Single)	200Vdc to 4kVdc
Output Voltage (Dual)	+/-100Vdc to +/-2kVdc
Total Output Power	10 Watts
Output Voltage Accuracy	+/- 3% (Full Load)
Line Regulation	Proportional
Load Regulation	< 35% (No Load to Full Load)
Output Ripple	< 6% P-P (Measured between + and - HVOut )
Startup Voltage	< 0.7Vdc
Efficiency	75% to 85% (typ.)
Output Short Circuit Protection	Continuous
Input to Output Isolation	2500 Vdc
Leakage Current	< 100nA
Input to Output Capacitance	< 60pF
Supervisory Circuits Enable Input	5Vdc @ 25mA
Remote On/Off	TTL Level Logic 0 (on)
Fault Control Signal Output	TTL Level Logic 1 (Fault Event)

*The appearance of products, including safety agency certifications pictured on labels, may change depending on the date manufactured. Specifications are subject to change without notice.*



## SPECIFICATIONS

ENVIROMENTAL	
Operating Temperature (case)	-55 to +85°C
Storage Temperature	-55 to +105°C
Temperature Stability	+/- 0.02%/°C
Humidity	0 to 95% (Non-Condensing)
Cooling	Free-Air Convection
Derating	None

GENERAL	
Input Filter	Low ESR Capacitor
EMI/RFI	>100kHz Quasi-Sinewave
Dimensions	1.08 x 2.19 x 0.50 Inches
Weight	1.4 Oz
Encapsulation Material	UL 94V-0 Epoxy (solid under vacuum)
Case Material	Black Phenolic / Metal

*The appearance of products, including safety agency certifications pictured on labels, may change depending on the date manufactured. Specifications are subject to change without notice.*



## 12Vdc INPUT MODELS

### REPRESENTATIVE MODEL LISTING

MODEL NUMBER		INPUT SPECIFICATIONS			OUTPUT SPECIFICATIONS			
Non-RoHs	RoHs	VOLTAGE	NO LOAD	FULL LOAD	VOLTAGE	CURRENT	LOAD REGULATION	RIPPLE
K10-12S20	K10-12S20/Y	0V to 12Vdc	<300 mA	<1.25 A	0V to 200Vdc	50 mA	35%	<6% P-P
K10-12S30	K10-12S30/Y	0V to 12Vdc	<300 mA	<1.25 A	0V to 300Vdc	33.3 mA	35%	<2% P-P
K10-12S50	K10-12S50/Y	0V to 12Vdc	<300 mA	<1.25 A	0V to 500Vdc	20 mA	35%	<2% P-P
K10-12S100	K10-12S100/Y	0V to 12Vdc	<300 mA	<1.25 A	0V to 1kVdc	10 mA	35%	<1% P-P
K10-12S200	K10-12S200/Y	0V to 12Vdc	<300 mA	<1.25 A	0V to 2kVdc	5 mA	35%	<2.25% P-P
K10-12S300	K10-12S300/Y	0V to 12Vdc	<300 mA	<1.25 A	0V to 3kVdc	3.33 mA	35%	<2% P-P
K10-12S400	K10-12S400/Y	0V to 12Vdc	<300 mA	<1.25 A	0V to 4kVdc	2.5 mA	35%	<1.5% P-P
K10-12D10	K10-12D10/Y	0V to 12Vdc	<300 mA	<1.25 A	0V to +/- 100Vdc	50 mA	35%	<6% P-P
K10-12D15	K10-12D15/Y	0V to 12Vdc	<300 mA	<1.25 A	0V to +/- 150Vdc	33.3 mA	35%	<2% P-P
K10-12D25	K10-12D25/Y	0V to 12Vdc	<300 mA	<1.25 A	0V to +/- 250Vdc	20 mA	35%	<2% P-P
K10-12D50	K10-12D50/Y	0V to 12Vdc	<300 mA	<1.25 A	0V to +/- 500Vdc	10 mA	35%	<1% P-P
K10-12D100	K10-12D100/Y	0V to 12Vdc	<300 mA	<1.25 A	0V to +/- 1kVdc	5 mA	35%	<2.5% P-P
K10-12D150	K10-12D150/Y	0V to 12Vdc	<300 mA	<1.25 A	0V to +/- 1.5kVdc	3.33 mA	35%	<2% P-P
K10-12D200	K10-12D200/Y	0V to 12Vdc	<300 mA	<1.25 A	0V to +/- 2kVdc	2.5 mA	35%	<1.5% P-P

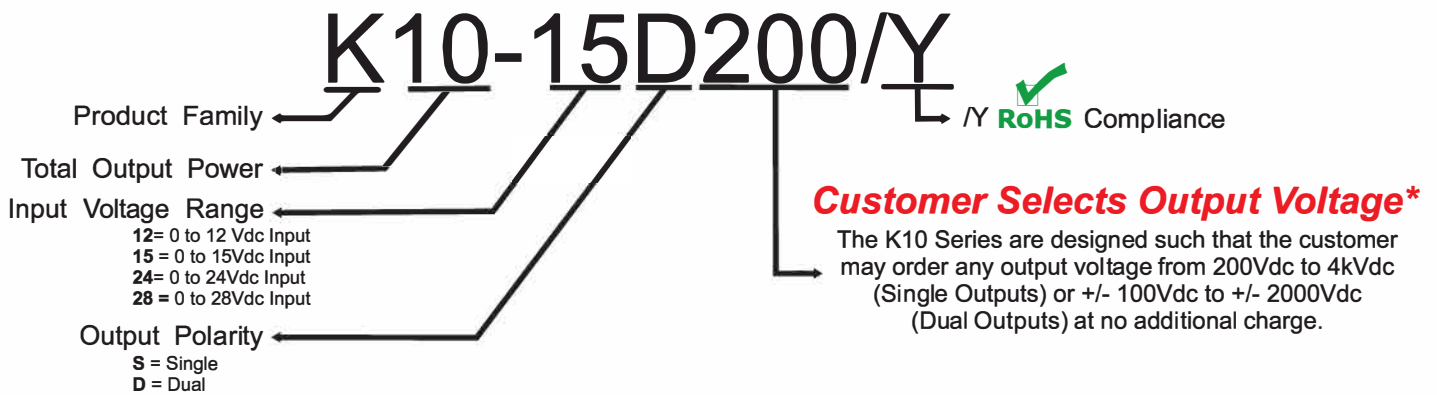

**\*ACTUAL OUTPUT VOLTAGE IS 10X**

The appearance of products, including safety agency certifications pictured on labels, may change depending on the date manufactured. Specifications are subject to change without notice.



## 15Vdc INPUT MODELS

### REPRESENTATIVE MODEL LISTING

MODEL NUMBER		INPUT SPECIFICATIONS			OUTPUT SPECIFICATIONS			
Non-RoHs	RoHs	VOLTAGE	NO LOAD	FULL LOAD	VOLTAGE	CURRENT	LOAD REGULATION	RIPPLE
K10-15S20	K10-15S20/Y	0V to 15Vdc	<250 mA	<1.15 A	0V to 200Vdc	50 mA	35%	<6% P-P
K10-15S30	K10-15S30/Y	0V to 15Vdc	<250 mA	<1.15A	0V to 300Vdc	33.3 mA	35%	<2% P-P
K10-15S50	K10-15S50/Y	0V to 15Vdc	<250 mA	<1.15 A	0V to 500Vdc	20 mA	35%	<2% P-P
K10-15S100	K10-15S100/Y	0V to 15Vdc	<250 mA	<1.15 A	0V to 1kVdc	10 mA	35%	<1% P-P
K10-15S200	K10-15S200/Y	0V to 15Vdc	<250 mA	<1.15 A	0V to 2kVdc	5 mA	35%	<2.25% P-P
K10-15S300	K10-15S300/Y	0V to 15Vdc	<250 mA	<1.15 A	0V to 3kVdc	3.33 mA	35%	<2% P-P
K10-15S400	K10-15S400/Y	0V to 15Vdc	<250 mA	<1.15 A	0V to 4kVdc	2.5 mA	35%	<1.5% P-P
K10-15D10	K10-15D10/Y	0V to 15Vdc	<250 mA	<1.15 A	0V to +/- 100Vdc	50 mA	35%	<6% P-P
K10-15D15	K10-15D15/Y	0V to 15Vdc	<250 mA	<1.15 A	0V to +/- 150Vdc	33.3 mA	35%	<2% P-P
K10-15D25	K10-15D25/Y	0V to 15Vdc	<250 mA	<1.15 A	0V to +/- 250Vdc	20 mA	35%	<2% P-P
K10-15D50	K10-15D50/Y	0V to 15Vdc	<250 mA	<1.15 A	0V to +/- 500Vdc	10 mA	35%	<1% P-P
K10-15D100	K10-15D100/Y	0V to 15Vdc	<250 mA	<1.15 A	0V to +/- 1kVdc	5 mA	35%	<2.5% P-P
K10-15D150	K10-15D150/Y	0V to 15Vdc	<250 mA	<1.15 A	0V to +/- 1.5kVdc	3.33 mA	35%	<2% P-P
K10-15D200	K10-15D200/Y	0V to 15Vdc	<250 mA	<1.15 A	0V to +/- 2kVdc	2.5 mA	35%	<1.5% P-P

*The appearance of products, including safety agency certifications pictured on labels, may change depending on the date manufactured. Specifications are subject to change without notice.*



## 24Vdc INPUT MODELS

### REPRESENTATIVE MODEL LISTING

MODEL NUMBER		INPUT SPECIFICATIONS			OUTPUT SPECIFICATIONS			
Non-RoHs	RoHs	VOLTAGE	NO LOAD	FULL LOAD	VOLTAGE	CURRENT	LOAD REGULATION	RIPPLE
K10-24S20	K10-24S20/Y	0V to 24Vdc	<150 mA	<650 mA	0V to 200Vdc	50 mA	35%	<6% P-P
K10-24S30	K10-24S30/Y	0V to 24Vdc	<150 mA	<650 mA	0V to 300Vdc	33.3 mA	35%	<2% P-P
K10-24S50	K10-24S50/Y	0V to 24Vdc	<150 mA	<650 mA	0V to 500Vdc	20 mA	35%	<2% P-P
K10-24S100	K10-24S100/Y	0V to 24Vdc	<150 mA	<650 mA	0V to 1kVdc	10 mA	35%	<1% P-P
K10-24S200	K10-24S200/Y	0V to 24Vdc	<150 mA	<650 mA	0V to 2kVdc	5 mA	35%	<2.25% P-P
K10-24S300	K10-24S300/Y	0V to 24Vdc	<150 mA	650 mA	0V to 3kVdc	3.33 mA	35%	<2% P-P
K10-24S400	K10-24S400/Y	0V to 24Vdc	<150 mA	<650 mA	0V to 4kVdc	2.5 mA	35%	<1.5% P-P
K10-24D10	K10-24D10/Y	0V to 24Vdc	<150 mA	<650 mA	0V to +/- 100Vdc	50 mA	35%	<6% P-P
K10-24D15	K10-24D15/Y	0V to 24Vdc	<150 mA	<650 mA	0V to +/- 150Vdc	33.3 mA	35%	<2% P-P
K10-24D25	K10-24D25/Y	0V to 24Vdc	<150 mA	<650 mA	0V to +/- 250Vdc	20 mA	35%	<2% P-P
K10-24D50	K10-24D50/Y	0V to 24Vdc	<150 mA	<650 mA	0V to +/- 500Vdc	10 mA	35%	<1% P-P
K10-24D100	K10-24D100/Y	0V to 24Vdc	<150 mA	<650 mA	0V to +/- 1kVdc	5 mA	35%	<2.5% P-P
K10-24D150	K10-24D150/Y	0V to 24Vdc	<150 mA	<650 mA	0V to +/- 1.5kVdc	3.33 mA	35%	<2% P-P
K10-24D200	K10-24D200/Y	0V to 24Vdc	<150 mA	<650 mA	0V to +/- 2kVdc	2.5 mA	35%	<1.5% P-P

*The appearance of products, including safety agency certifications pictured on labels, may change depending on the date manufactured. Specifications are subject to change without notice.*



## 28Vdc INPUT MODELS

### REPRESENTATIVE MODEL LISTING

MODEL NUMBER		INPUT SPECIFICATIONS			OUTPUT SPECIFICATIONS			
Non-RoHs	RoHs	VOLTAGE	NO LOAD	FULL LOAD	VOLTAGE	CURRENT	LOAD REGULATION	RIPPLE
K10-28S20	K10-28S20/Y	0V to 28Vdc	<150 mA	<625 mA	0V to 200Vdc	50 mA	35%	<6% P-P
K10-28S30	K10-28S30/Y	0V to 28Vdc	<150 mA	<625 mA	0V to 300Vdc	33.3 mA	35%	<2% P-P
K10-28S50	K10-28S50/Y	0V to 28Vdc	<150 mA	<625 mA	0V to 500Vdc	20 mA	35%	<2% P-P
K10-28S100	K10-28S100/Y	0V to 28Vdc	<150 mA	<625 mA	0V to 1kVdc	10 mA	35%	<1% P-P
K10-28S200	K10-28S200/Y	0V to 28Vdc	<150 mA	<625 mA	0V to 2kVdc	5 mA	35%	<2.25% P-P
K10-28S300	K10-28S300/Y	0V to 28Vdc	<150 mA	<625 mA	0V to 3kVdc	3.33 mA	35%	<2% P-P
K10-28S400	K10-28S400/Y	0V to 28Vdc	<150 mA	<625 mA	0V to 4kVdc	2.5 mA	35%	<1.5% P-P
K10-28D10	K10-28D10/Y	0V to 28Vdc	<150 mA	<625 mA	0V to +/- 100Vdc	50 mA	35%	<6% P-P
K10-28D15	K10-28D15/Y	0V to 28Vdc	<150 mA	<625 mA	0V to +/- 150Vdc	33.3 mA	35%	<2% P-P
K10-28D25	K10-28D25/Y	0V to 28Vdc	<150 mA	<625 mA	0V to +/- 250Vdc	20 mA	35%	<2% P-P
K10-28D50	K10-28D50/Y	0V to 28Vdc	<150 mA	<625 mA	0V to +/- 500Vdc	10 mA	35%	<1% P-P
K10-28D100	K10-28D100/Y	0V to 28Vdc	<150 mA	<625 mA	0V to +/- 1kVdc	5 mA	35%	<2.5% P-P
K10-28D150	K10-28D150/Y	0V to 28Vdc	<150 mA	<625 mA	0V to +/- 1.5kVdc	3.33 mA	35%	<2% P-P
K10-28D200	K10-28D200/Y	0V to 28Vdc	<150 mA	<625 mA	0V to +/- 2kVdc	2.5 mA	35%	<1.5% P-P

*The appearance of products, including safety agency certifications pictured on labels, may change depending on the date manufactured. Specifications are subject to change without notice.*



## PRODUCT DIMENSIONS

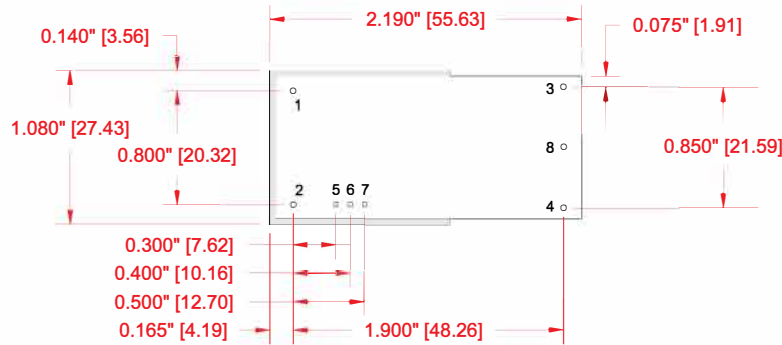

**Bottom View**

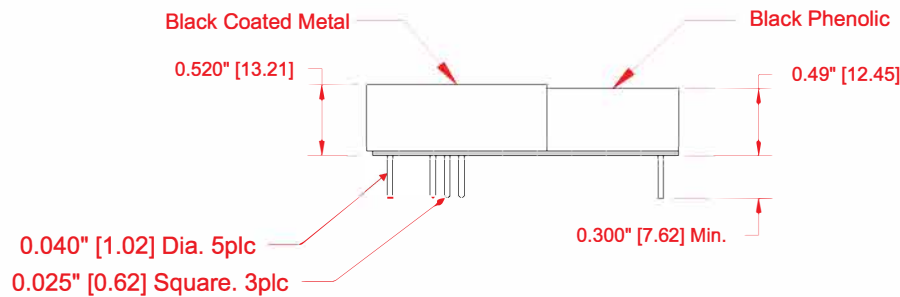

*Dimensions are in Inches  
[Metric equivalents in brackets]*

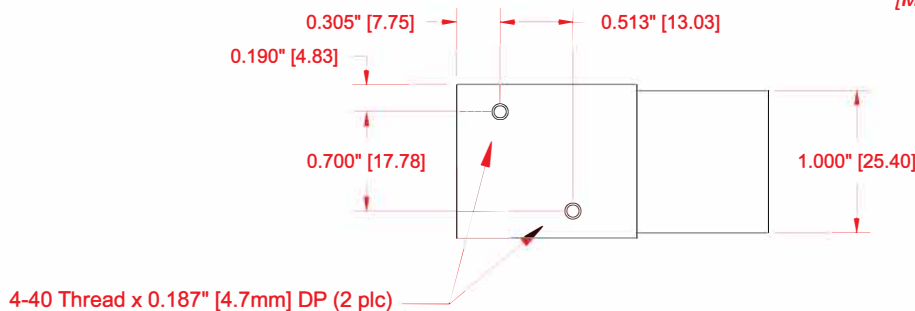

PIN #	FUNCTION	PIN #	FUNCTION
1	+ Input	5	Fault Output
2	- Input	6	+5V Input
3	+ Output	7	On/Off
4	- Output	8	Output Common (Dual output only)



*The appearance of products, including safety agency certifications pictured on labels, may change depending on the date manufactured. Specifications are subject to change without notice.*





## K10-ADPT VERTICAL MOUNT ADAPTER BOARD

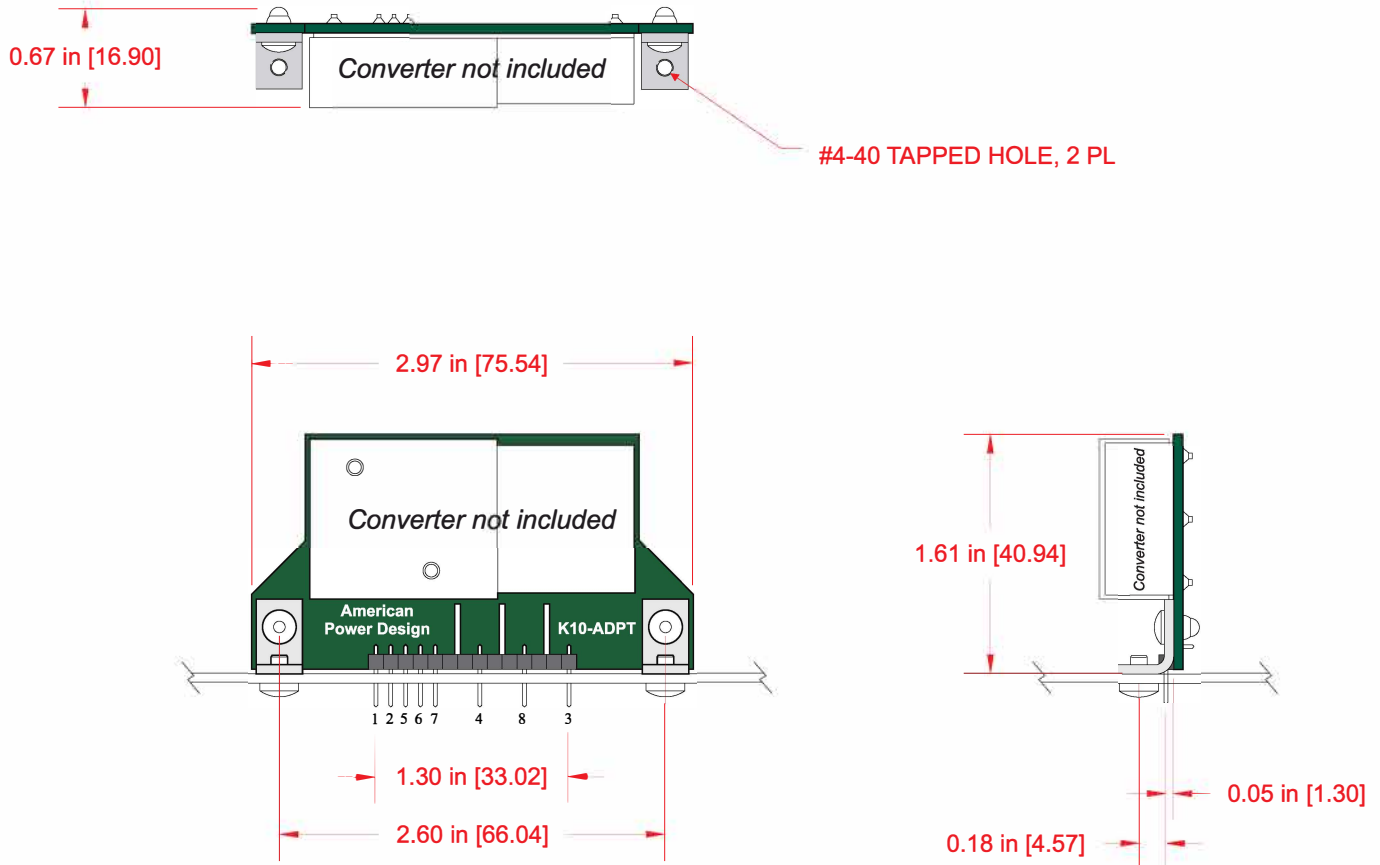

PIN #	FUNCTION	PIN #	FUNCTION
1	+ Input	5	Fault Output
2	- Input	6	+5V Input
3	+ Output	7	On/Off
4	- Output	8	NC (Single) Output Common (Dual)

The K10-ADPT adaptor board provides a convenient way to mount any K10 Series converter on its side, minimizing board real estate.

Please note K10 Series converter is not included and must be ordered separately.

*The appearance of products, including safety agency certifications pictured on labels, may change depending on the date manufactured. Specifications are subject to change without notice.*



## K10-EVAL - EVALUATION MODULE

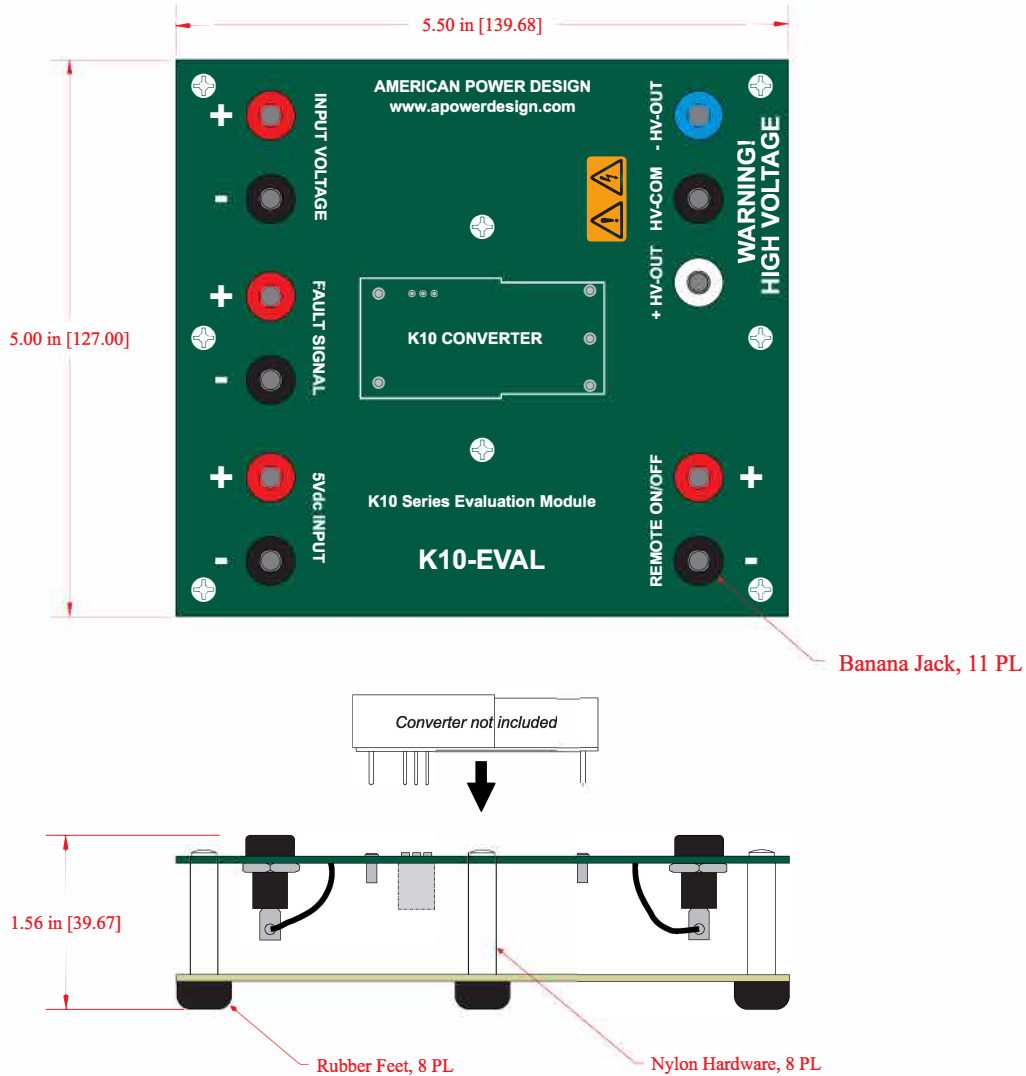

The K10-EVAL evaluation board provides an easy and convenient means of prototyping and evaluating all K10 Series converters without having to mount it directly onto a PC board.

Please note K10 Series converter is not included and must be ordered separately.

*The appearance of products, including safety agency certifications pictured on labels, may change depending on the date manufactured. Specifications are subject to change without notice.*



## APPLICATION NOTES

### Input and Output Impedence

The K10 Series of power converters have been designed to be stable with no external capacitors when used in low inductance input and output circuits. However, in some applications, the inductance associated with the distribution from the power source to the input of the converter can affect the stability of the converter. The addition of a 10  $\mu$ F electrolytic capacitor with an ESR <1 Ohm across the input helps ensure stability of the converter. In some applications, the user may need to use decoupling capacitance at the load.

### Short Circuit Protection

The K10 Series is equipped with short circuit protection. The converter will fold-back the input power whenever a short circuit is applied to its output and automatically recover after the overload condition is removed.

### Input to Output Isolation

The Output of the K10 Series is galvanically isolated from the input, capacitance is < 60pF and resistance is > 10G Ohm. Isolation permits up to a 2500V bias on the output return.

### Output Ripple and Noise

Figure below shows a typical output voltage ripple waveform, measured at full rated load current with no additional output filtering. External low ESR capacitors may be added across output to further reduce ripple.

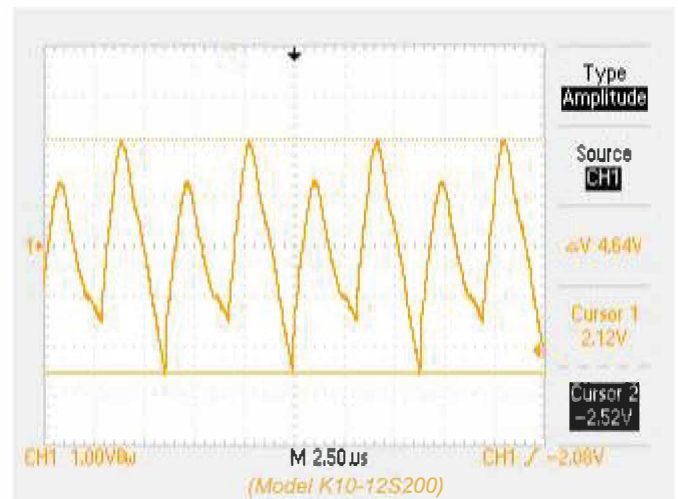

*The appearance of products, including safety agency certifications pictured on labels, may change depending on the date manufactured. Specifications are subject to change without notice.*



## APPLICATION NOTES

### Remote On/Off Control

The On/Off control pin (Pin 7) allows the user to shut down the converter using a TTL High signal.

The On/Off control pin (Pin 7) may also be connected directly to the Fault pin (Pin 5) to create a self latching converter that will remain disabled when a fault condition is detected until the converter is reset by toggling the 5V input (Pin 6) low for >250ms.

### Thermal and Voltage Monitoring

The K10 Series is equipped with supervisory circuits that actively monitor input voltage and internal temperature providing automatic protection from over-voltage and over-temperature. Should preset limits be exceeded, the power supply will be temporarily disabled. A TTL-compatible, latching (high) signal alarm condition will occur (Pin 5).

Once the fault condition is cleared the converter will automatically restart. However, the fault signal will remain set (TTL high) until the 5V input (Pin 6) is toggled low for >250ms.

#### Input Voltage Preset Fault Limits:

12Vdc Input = >13.5 Vdc  
15Vdc Input = >16.5 Vdc  
24Vdc Input = >27Vdc  
28Vdc Input = >31Vdc

#### NOTE:

*Sustained presence of an input over-voltage may cause permanent damage. It is recommended that the input voltage be disabled in responses to the fault alarm.*

Temperature Preset Limit: >90°C

### Output Voltage Tracking

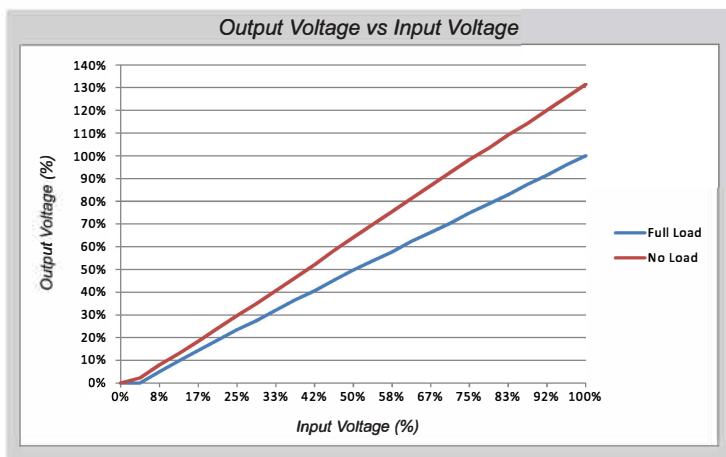

The output voltage of the K10 Series is directly proportional to the input voltage starting at <0.7Vdc In.

The graph to the left illustrates how the output voltage tracks the input voltage at both no load and full load.

*The appearance of products, including safety agency certifications pictured on labels, may change depending on the date manufactured. Specifications are subject to change without notice.*



## APPLICATION NOTES

### Inrush Current

The inrush current of the K10 Series has been kept as low as possible. However, a series resistor may be inserted in the input line to limit this current further.

### Rise Time

Figures below show typical output voltage rise time for both no load current and full rated load current.

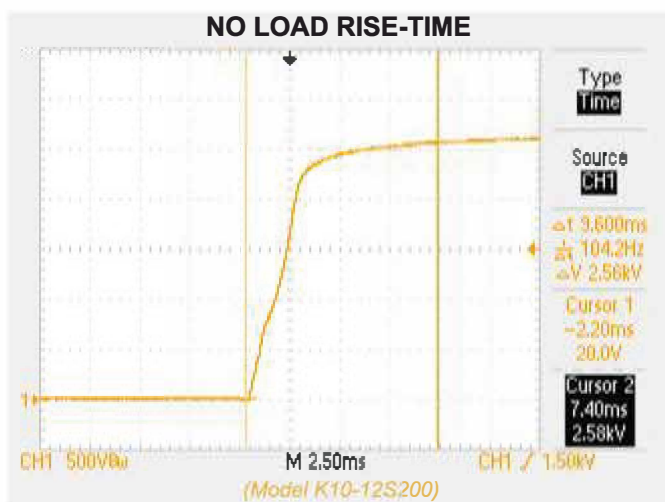

### Load Transients

Figures below show typical output voltage response, measured during a transition from full rated load current to no load current and from no load current to full rated load current with no additional output filtering.

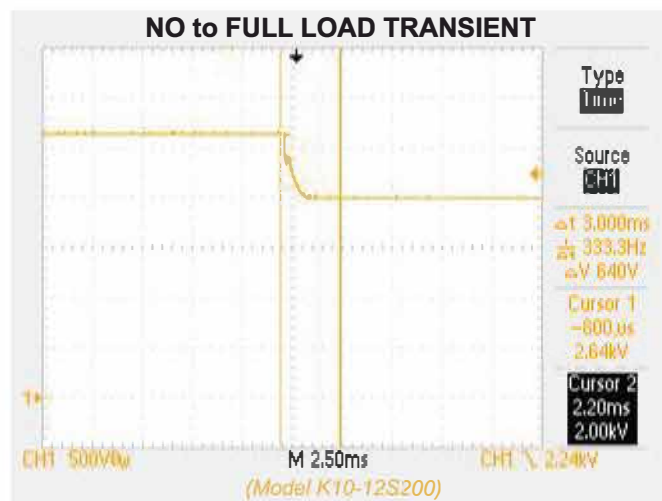
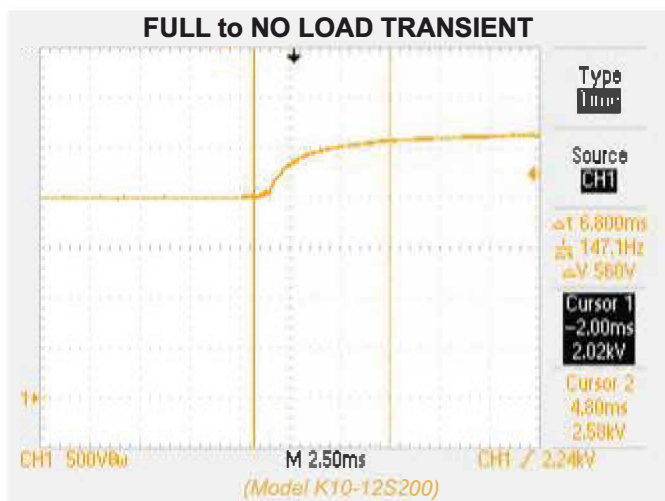

*The appearance of products, including safety agency certifications pictured on labels, may change depending on the date manufactured. Specifications are subject to change without notice.*



## APPLICATION NOTES

### Positive and Negative Output Wiring

Isolated DC-DC voltage converters can provide positive or negative voltages from a single device.

The figures below show the typical connections for both a positive and negative output relative to ground.

#### POSITIVE OUTPUT

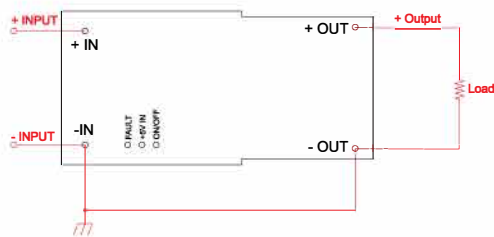

#### NEGATIVE OUTPUT

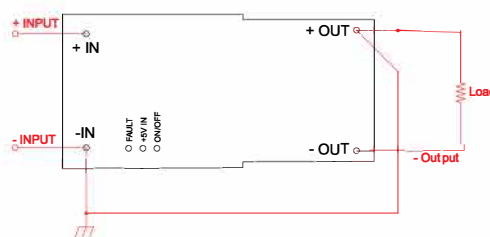

### Multiple Converters in Series

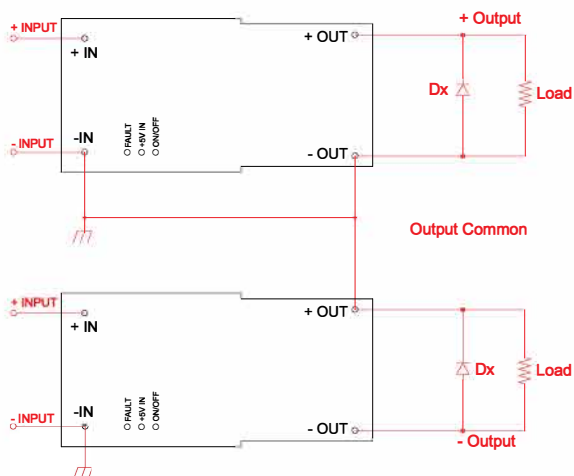
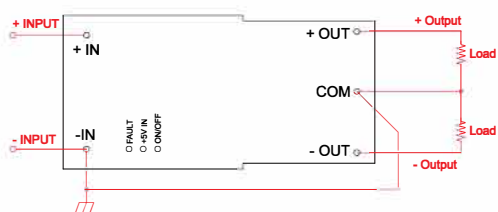

Figure to the left shows how to create a 20W dual output supply using two converters in series with the use of shunt diodes, taking into consideration that the highest achieved output voltage should remain below the rated isolation voltage.

**NOTE:**

*The ratings of Dx should be 1.5 times the maximum current and voltage expected in each branch.*

### Dual Output Wiring



Isolation on a dual output converter is from Com output pin (8) and -Input (2) and therefore ground connection on the output is to Com pin only.

The figure to the left shows the typical connections relative to ground.

*The appearance of products, including safety agency certifications pictured on labels, may change depending on the date manufactured. Specifications are subject to change without notice.*



## APPLICATION NOTES

### Grounding Considerations

High voltage power supply grounding is an important part of any high voltage application. Proper grounding is essential for all electrical systems, devices, and equipment. It is necessary for safety purposes and helps to protect electronics and provide stability by preventing voltage fluctuations. The earth ground serves as a reference point for the voltage of the system and provides a path for electrical current to flow to the earth in the event of arcing, which is a common occurrence in high voltage applications.

Working with high voltage is unpredictable and can lead to arcing and corona discharges, which are uncontrolled events that can cause bodily harm and damage electronics. To prevent these issues, it is important to have an independent ground connection to the earth in a high voltage system. The higher the voltage, the more critical it becomes to manage the ground path and establish the proper high voltage power supply grounding technique.

When using a high voltage power supply, it is often necessary to connect it to other modules and sub-assemblies, which means managing multiple ground paths. It is important to properly manage these ground paths to ensure the high voltage output is stable and accurate. Inaccurate or unstable high voltage output can cause problems with the system and make it difficult to obtain reliable results.

#### Input Power Return

AC-DC switching power supplies are often used to power APD's high voltage converters. However, switching power supplies can contain noise, therefore proper grounding is an important part of the equipment design. To prevent these problems, APD's high voltage converters are designed to ensure that the input return does not share a path with the sensitive control circuits. Properly managing the grounding and separating the different parts of the system can help to ensure reliable and accurate operation of APD converter.

#### Input Signal Ground

Gain and signal-to-noise ratio (SNR) are two factors that can significantly impact the performance. Gain refers to the extent to which a signal is amplified or increased in strength. For example a high voltage converter that converts an input of 0 to 12 V to an output of 0 to 1200 V has a gain of 100. SNR, on the other hand, is a measure of the strength of a signal in relation to the level of noise or interference present. Generally, higher gain and SNR values are desirable as they can improve the accuracy and reliability of a converter. However, it's also crucial to properly set the Gain and SNR to prevent system overload and other issues. For example excessive gain can cause distortion in the output signal, while high SNR can reduce the system's sensitivity to weak signals or small input changes.

#### High Voltage Ground

High voltage can be unpredictable and may result in dangerous events such as arcing and corona discharges, which can cause harm to individuals and equipment. It is important to take proper precautions when working with high voltage, including proper high voltage power supply grounding.

The output ground or high voltage return can be a source of many issues. The amount of energy stored in the output filtering stage of the high voltage converter can be significant. This means that the amount of energy transferred during a high voltage discharge or arc if not controlled can reach destructive levels. The resulting high current surge can cause voltage transients on the ground path, which can damage low voltage circuits if not routed properly.

To prevent these issues, it is important to directly route the high voltage return path to the high voltage return on the power supply. Failure to use proper grounding techniques can lead to reliability problems in the field due to high voltage discharges.

*The appearance of products, including safety agency certifications pictured on labels, may change depending on the date manufactured. Specifications are subject to change without notice.*



## APPLICATION NOTES

### High Voltage Safety

High voltage power supplies present a serious risk of personal injury if not used in accordance with APD's specifications.

Before using APD's products, read, understand and thereafter adhere to all instructions, protocol, cautions and safety procedures applicable not only to APD's products but to each product and/or application into which APD's products are incorporated or assembled.

Simple safety practices such as checking to see that the work area is dry and uncluttered, an outlet is not overloaded, or that a cord is not frayed can go a long way in helping to prevent fire, shock, or electrical burns.

Any exposed conducting surface should be considered hazardous if the voltage is higher than 50 V however voltage alone is far from the whole story: circuits with low voltages can sometimes deliver hazardous current and/or stored energy. For example, superconducting magnets can operate with low voltage drops but high current and high stored energy, and low voltage buses can sometimes be capable of delivering high current. Due to high capacitance or inductance, even disconnected circuits can have high stored energy. Moreover, abnormal conditions (e.g. the contact area with or path taken through the body, ambient humidity, individual perspiration level, the presence of water on or near the circuit) can increase the hazard level for any given voltage or current. For DC voltages, currents above 25 mA at 50 V are considered hazardous under normal conditions.

Another hazard of working with high voltage is that of "arc flash". An arc flash occurs when an unintended low impedance current path becomes available to a circuit capable of supplying high current, and results in an explosion which blasts molten metal and an expanding plasma with great force and extremely high temperatures. Serious injury and death can occur for anyone in the vicinity of an arc flash, especially if appropriate protective equipment is not worn. An arc-flash hazard may exist at some AC power distribution panels, with the danger being highest for higher voltages and power capabilities. Specialized training is necessary to work in the vicinity of any arc-flash hazard.

### Safety/Regulatory Requirements

The converters meet North American and International safety regulatory requirements per CAN/CSA C22.2 No 62368-1:2014 / UL 62368-1:2014 / EN62368-1:2014/A11:2017. To comply with safety agencies requirements, an input line fuse must be used external to the converter. The table below provides the recommended fuse rating for use with this family of products.

If one input fuse is used for a group of modules, the maximum fuse rating should not exceed 5A.

Input Voltage	Fuse Rating
12Vdc & 15Vdc	2A
24Vdc & 28Vdc	1A

*The appearance of products, including safety agency certifications pictured on labels, may change depending on the date manufactured. Specifications are subject to change without notice.*





## APPLICATION NOTES

### Hand Soldering

Before soldering the use of flux may prove to be useful especially in case of lead free process. Keep the use of flux to a minimum to ease cleaning. If you do use flux apply it sparingly to the pins, the pads and plated holes. The soldering assembly must be undertaken with a minimum 80W iron and a solder tip at a temperature below 380C (measured temperature) for leaded alloys and 420°C for lead free alloys. Soldering iron must be in contact with the pins for at least 5 seconds.

### Cleaning Agents

In order to avoid possible damage, any penetration of cleaning fluids must be prevented, since the power supplies are not hermetically sealed.

### Nuclear and Medical Applications

American Power Design products are not designed, intended for use in, or authorized for use as critical components in life support systems, equipment used in hazardous environments, or nuclear control systems without the express written consent of American Power Design, Inc.

### Warranty

All products manufactured by American Power Design, Inc. (APD) are warranted to be free of defects due to material or workmanship for a period of three years from date of shipment. At our option, APD will repair or replace any non-conforming product.

APD expressly disclaims any liability for consequential or incidental damages resulting from the use or misuse of its products by the purchaser or others.

This warranty is in lieu of all warranties expressed or implied, including the warranties of merchantability. No other warranties, obligations, or liabilities are expressed or implied.

All products being returned for repair require a return material authorization(RMA) assigned by APD prior to return shipment.

*The appearance of products, including safety agency certifications pictured on labels, may change depending on the date manufactured. Specifications are subject to change without notice.*