

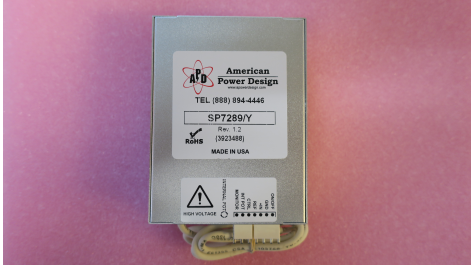

"The best high voltage design solution"

SP7289 10W, -15kV, SPECIFICATION SHEET



Standard Model Number : **SP7289**

RoHS Model Number : **SP7289/Y**

ELECTRICAL SPECIFICATIONS

Standard Model is NOT RoHS Compliant

Input Voltage	22.8V to 28.8Vdc	Programming Voltage	0 - 5Vdc
Input Current	<180mA (No Load)	Programming Current	< 100uA
Input Current	<900mA (Full Load)	Programming Linearity	<0.5% (5% to 100% Vout)
Output Voltage	0V to -15kVdc (Programmable)	Input Filter	Low ESR Capacitor
Output Current	0.67 mA	Reverse Input Protection	30A @ 5mS (Shunt)
Voltage Accuracy	< 1.5%	Short Circuit Protection	Continuous
Line Regulation	< 0.1%	Switching Frequency	170 kHz
Load Regulation	<0.2%	Response Time	<900 ms (Full Load, full scale response)
Output Ripple	< 0.1% (15V P-P)	Programming Voltage Shutdown	> 5.2Vdc
		Output Voltage Monitor	0 to -5Vdc = 0 to -15kVdc
		On/Off	ON=N.C. or 0Vdc / OFF=5Vdc

GENERAL SPECIFICATIONS

Stability	< 0.01% / Hr.	Humidity	0 to 95% (Non-Condensing)
Temp. Stability	+/- 0.005%/°C	EMI/RFI	Six-Sided Shield
Temp. (Operating , Case)	-10 to +60°C	Derating	None
Temp. (Storage)	-40 to +125°C	Cooling	Free-Air Convection
Thermal Shock Limit	1°C / 10 Seconds		

PHYSICAL SPECIFICATIONS

Dimensions	3.1 x 4.1 x 1.4 inches	Encapsulation Material	UL94V-0 Epoxy
Weight	18.6 Oz	Case Material	Anodized Aluminum



European Stocking Distributor
Phone: +41 44 730 33 53
Email: sales@hvps-condatas.com · www.hvps-condatas.com
Rietbachstrasse 7 · 8952 Schlieren (ZH) · Switzerland



"The best high voltage design solution"

SP7289 10W, -15kV, SPECIFICATION SHEET

Dimensions are in Inches
[Metric equivalents in brackets]

MOLEX CONNECTOR
KK Series 0026605070

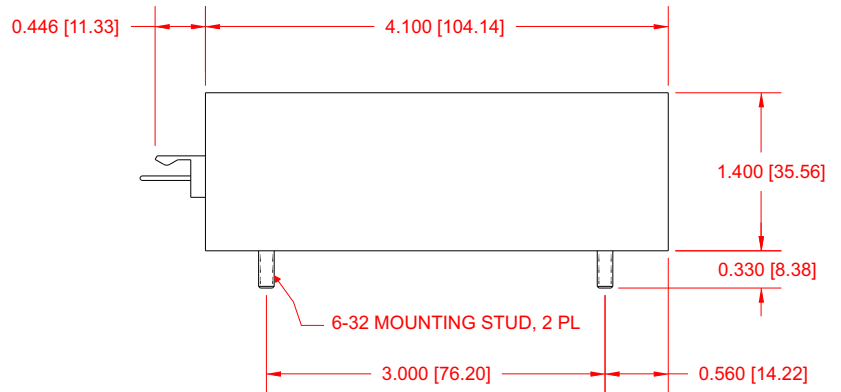
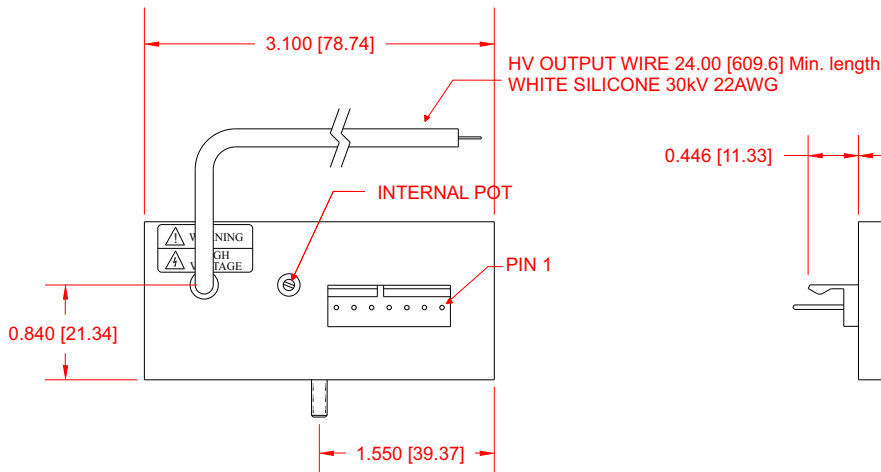
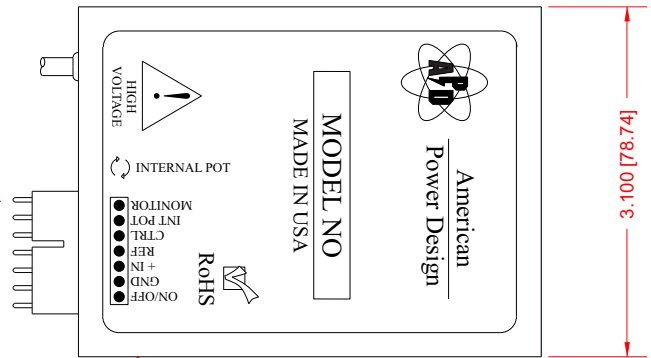

PIN #	FUNCTION
1	On/Off
2	Gnd / Case
3	+ Input
4	5V Reference
5	Control / Programming Voltage
6	Internal Potentiometer
7	Output Voltage Monitor

MATING CONNECTOR: Molex 009503071 (Supplied)
18-24 AWG CRIMP TERMINALS: Molex 008500106 (Supplied)



"The best high voltage design solution"

SP7289 10W, -15kV, SPECIFICATION SHEET

APPLICATION NOTES

INRUSH CURRENT

The inrush current has been kept as low as possible. However, a series resistor may be inserted in the input line to limit this current further.

REVERSE INPUT PROTECTION

The SP7289 is equipped with a shunt diode placed in parallel with + Input (Pin 3) and GND (Pin 2) of the converter, this allows high current to flow if the incorrect polarity is applied.

SHORT CIRCUIT PROTECTION

The converter will fold-back the input power whenever a short circuit is applied to its output and automatically recover after the overload condition is removed.

NOTE:
Input fuse must not exceed 30A otherwise the supply may be permanently damaged.

RIPPLE AND NOISE

External low ESR capacitors may be added across output to further reduce ripple.

PROGRAMMING

There are three typical methods to programming the SP7289.

Analog Control:
Apply a 0V to 5Vdc signal to the Control / Programming input (Pin 5).

Manual Remote:
Connecting 1 side of an external potentiometer to the 5V Reference output (Pin 4), The Wiper arm to the Control / Programming input (Pin 5), and the remaining end to GND (Pin 2).

Onboard Potentiometer:
Connect internal pot (Pin 6) to Control / Programming (Pin 5).

PROGRAMMING VOLTAGE

A 0V to +5V signal will program the power supply for 0 to 100% rated output voltage. The input impedance for this control pin is typically 100KΩ. If the programming signal exceeds 5.2Vdc the converter will shutdown and automatically recover when the programming signal returns to within normal operating range.

OUTPUT VOLTAGE TRACKING

The output voltage tracks the Control pin (Pin 5) within 0.5% from 5% to 100% of output voltage.

Figure below show a typical plot of both the actual and calculated output voltage as a function of control voltage.

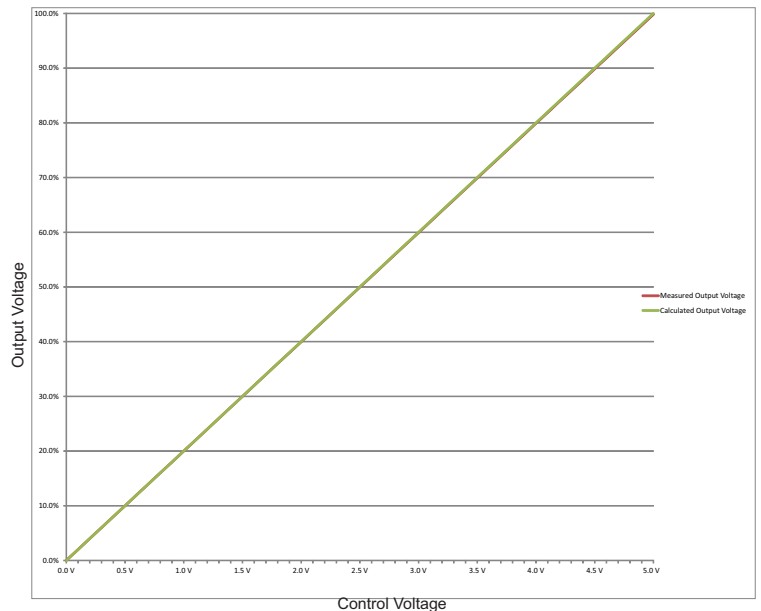

Operating Conditions:

Nominal Input Voltage = Fixed
Output Load = Resistive (fixed at full output current @ 100% output voltage)



"The best high voltage design solution"

SP7289 10W, -15kV, SPECIFICATION SHEET

APPLICATION NOTES

CLEANING AGENTS

In order to avoid possible damage, any penetration of cleaning fluids must be prevented, since the power supplies are not hermetically sealed.

NUCLEAR AND MEDICAL APPLICATIONS

American Power Design products are not designed, intended for use in, or authorized for use as critical components in life support systems, equipment used in hazardous environments, or nuclear control systems without the express written consent of American Power Design, Inc.

SAFETY REQUIREMENTS

The converters are designed to meet North American and International safety regulatory requirements per UL 60950-1/CSA 22.2 No. 60950-1-07 Second Edition, IEC 60950-1:2005, and EN 60950-1:2006. Basic Insulation is provided between input and output. To comply with safety agencies requirements, an input line fuse (2A SB) must be used external to the converter.

If one input fuse is used for a group of modules, the maximum fuse rating should not exceed 20A.

WARRANTY

All products manufactured by American Power Design, Inc. (APD) are warranted to be free of defects due to material or workmanship for a period of one year from date of shipment. At our option, APD will repair or replace any non-conforming product.

APD expressly disclaims any liability for consequential or incidental damages resulting from the use or misuse of its products by the purchaser or others.

This warranty is in lieu of all warranties expressed or implied, including the warranties of merchantability. No other warranties, obligations, or liabilities are expressed or implied.

All products being returned for repair require a return material authorization(RMA) assigned by APD prior to return shipment.