



"The best high voltage design solution"

# SP7226, 0.5W, with ext. Shield, PROPORTIONAL, SPEC. SHEET



**Standard Model Number : SP7226**

**RoHs Model Number : SP7226/Y** 

## ELECTRICAL SPECIFICATIONS

*Standard Model is NOT RoHs Compliant*

Input Voltage .....	0-5Vdc	Input Filter .....	Low ESR Capacitor
Output Voltage .....	0 to + or -1000Vdc	No Load Input current .....	< 100mA
Output Current .....	0.5mA	Full Load Input current .....	< 250mA
Voltage Accuracy .....	+/- 10% (Full Load)	Short Circuit Protection .....	Continuous
Line Regulation .....	Proportional	Switching Frequency .....	180 kHz
Load Regulation .....	+/- 20%	Output Isolation .....	500 Vdc Bias on HV Output
Output Ripple .....	< 0.25% P-P	Input / Output Capacitance .....	< 30pF
Start-up Voltage .....	< 0.7Vdc		

## GENERAL SPECIFICATIONS

Temp. Stability .....	+/- 0.02%/°C	Derating .....	None
Temp. (Operating , Case) .....	-25 to +75°C	Cooling .....	Free-Air Convection
Temp. (Storage) .....	-55 to +100°C		
Humidity .....	0 to 95% (Non-Condensing)		

## PHYSICAL SPECIFICATIONS

Dimensions .....	0.54 x 0.54 x 0.52 inches	Case Material .....	Nickel Plated Metal
Weight .....	0.25 Oz		



"The best high voltage design solution"

**SP7226, 0.5W, with ext. Shield, PROPORTIONAL, SPEC. SHEET**

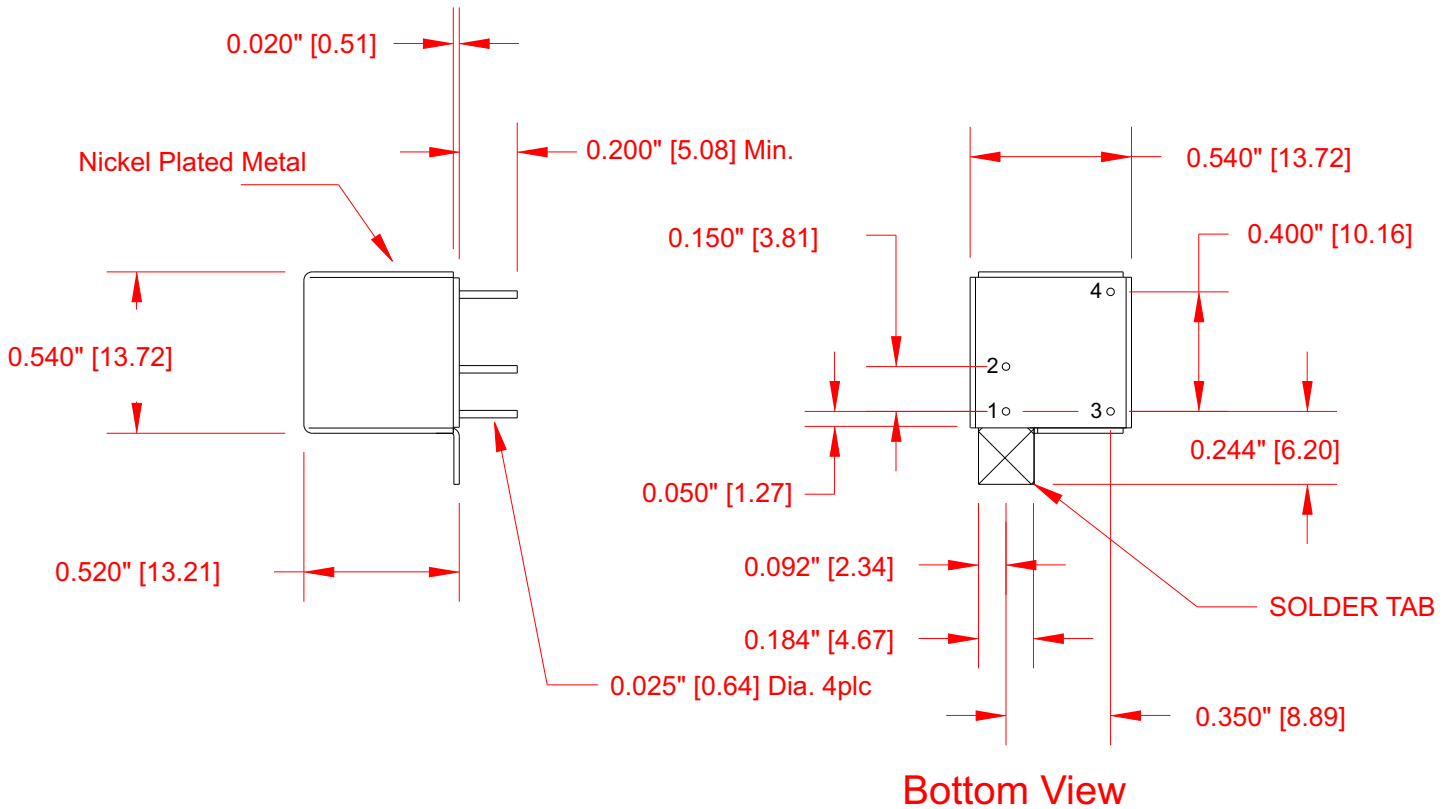

*Dimensions are in Inches  
[Metric equivalents in brackets]*

PIN #	FUNCTION
1	- Input
2	+ Input
3	+ HV Output
4	- HV Output



"The best high voltage design solution"

## SP7226, 0.5W, with ext. Shield, PROPORTIONAL, SPEC. SHEET

### APPLICATION NOTES

#### CLEANING AGENTS

In order to avoid possible damage, any penetration of cleaning fluids must be prevented, since the power supplies are not hermetically sealed.

#### NUCLEAR AND MEDICAL APPLICATIONS

American Power Design products are not designed, intended for use in, or authorized for use as critical components in life support systems, equipment used in hazardous environments, or nuclear control systems without the express written consent of American Power Design, Inc.

#### SAFETY REQUIREMENTS

The converters are designed to meet North American and International safety regulatory requirements per UL 60950-1/CSA 22.2 No. 60950-1-07 Second Edition, IEC 60950-1:2005, and EN 60950-1:2006. Basic Insulation is provided between input and output. To comply with safety agencies requirements, an input line fuse (0.5A SB) must be used external to the converter.

If one input fuse is used for a group of modules, the maximum fuse rating should not exceed 5A.

#### WARRANTY

All products manufactured by American Power Design, Inc. (APD) are warranted to be free of defects due to material or workmanship for a period of one year from date of shipment. At our option, APD will repair or replace any non-conforming product.

APD expressly disclaims any liability for consequential or incidental damages resulting from the use or misuse of its products by the purchaser or others.

This warranty is in lieu of all warranties expressed or implied, including the warranties of merchantability. No other warranties, obligations, or liabilities are expressed or implied.

All products being returned for repair require a return material authorization(RMA) assigned by APD prior to return shipment.