

**COMPACT HIGH VOLTAGE OP AMP**

**PAD195**

*Preliminary Information*

*Rev D*

**KEY FEATURES**

- **LOW COST**
- **SMALL SIZE 40mm SQUARE**
- **HIGH VOLTAGE – 1040 VOLTS**
- **OUTPUT CURRENT– 100mA**
- **10 WATT DISSIPATION CAPABILITY**
- **3V/μS SLEW RATE**
- **1mA QUIESCENT CURRENT**

**APPLICATIONS**

- **HIGH VOLTAGE INSTRUMENTATION**
- **PIEZO TRANSDUCER DRIVE**
- **ELECTRON BEAM FOCUSING**
- **PROGRAMMABLE VOLTAGE SOURCE**

**DESCRIPTION**

The PAD195 compact high voltage op amp is constructed with surface mount components to provide a cost effective solution for many industrial applications such as high voltage instrumentation. With a footprint only 40mm square the PAD195 offers outstanding performance that rivals more expensive hybrid components. Integrated passive heat sink cooling is included. User selectable external compensation tailors the amplifier’s response to the application requirements. A single resistor programs the current limit feature. The PAD195 is built on a thermally conductive but electrically insulating substrate. No BeO is used in the PAD195. For custom applications the PAD195-1 version of the amplifier is available without the integrated heat sink. The circuit is conformal coated for additional safety and reliability. See “CONFORMAL COATING” paragraph on page 5.



PAD195



PAD195-1

**A NEW CONCEPT**

A critical task in any power amplifier application is cooling the amplifier. Until now component amplifier manufacturers often treated this task as an after-thought, left for the user to figure out. At **Power Amp Design** the best heat sink is chosen at the start and becomes an integral part of the overall amplifier design. The result is the most compact and volumetric efficient design combination at the lowest cost. In addition, this integrated solution concept offers an achievable real-world power dissipation rating, not the ideal rating usually cited when the amplifier case is somehow kept at 25°C. The user no longer needs to specify, procure or assemble separate components.

**Power Amp Design ♦ PAD195 ♦ COMPACT HIGH VOLTAGE OP AMP**

**EQUIVALENT CIRCUIT**

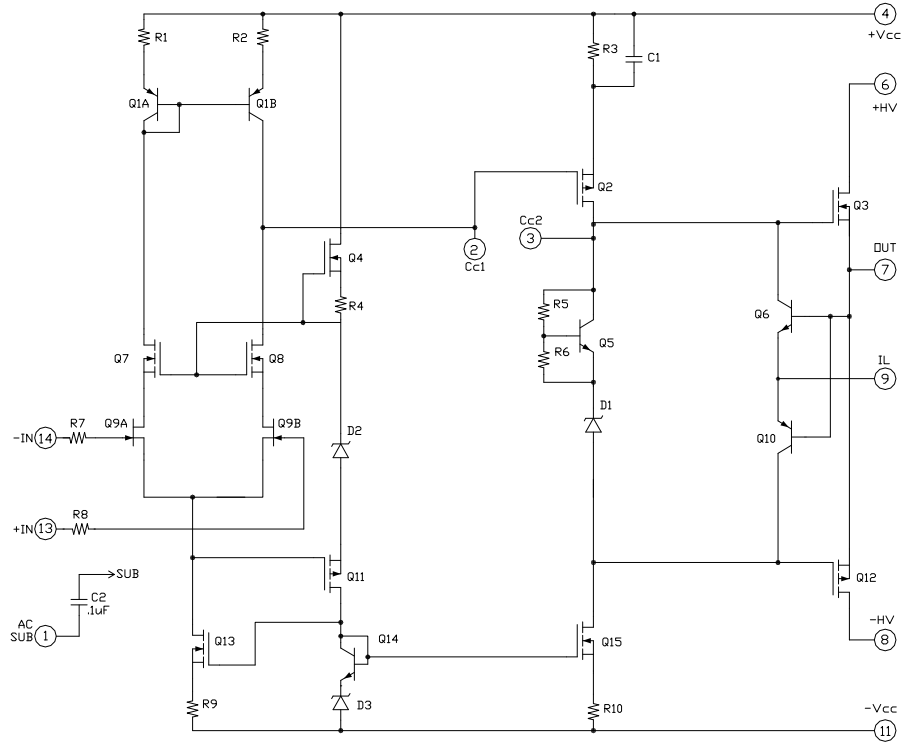

**PINOUT & CONNECTIONS**

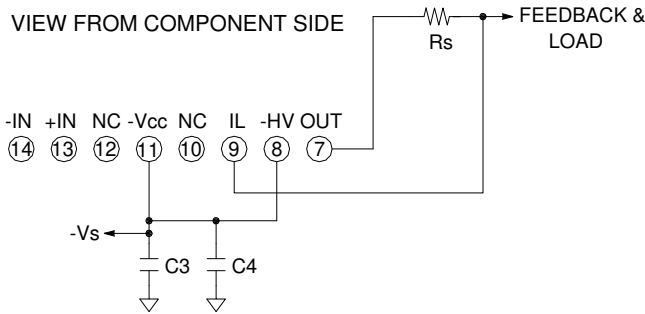
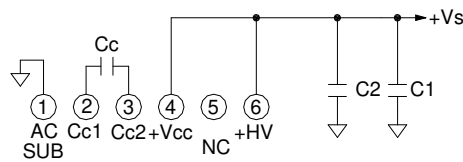

PHASE COMPENSATION		SLEW RATE
GAIN	Cc	
≥20	10pF	30V/uS
≥10	22pF	20V/uS

**Power Amp Design ♦ PAD195 ♦ COMPACT HIGH VOLTAGE OP AMP**

ABSOLUTE MAXIMUM RATINGS			
SUPPLY VOLTAGE, +HV to -HV <sup>4</sup>	1040V	TEMPERATURE, pin solder,	10s, 300°C
SUPPLY VOLTAGE, +Vcc to -Vcc <sup>4</sup>	1040V	TEMPERATURE, junction <sup>2</sup>	150°C
INPUT VOLTAGE	+Vcc to -Vcc	TEMPERATURE RANGE, storage	-40 to 105°C
DIFFERENTIAL INPUT VOLTAGE	± 20V	TEMPERATURE RANGE, storage, PAD195-1	105°C
OUTPUT CURRENT, peak, within SOA	0.2A	OPERATING TEMPERATURE, substrate	-40 to 85°C
POWER DISSIPATION, internal, DC	10W		

PARAMETER	TEST CONDITIONS <sup>1</sup>	MIN	TYP	MAX	PAD135-1 <sup>9</sup>	UNITS
<b>INPUT</b>						
OFFSET VOLTAGE			0.5	2		mV
OFFSET VOLTAGE vs. temperature	Full temperature range		4	15		μV/°C
OFFSET VOLTAGE vs. supply				1		μV/V
BIAS CURRENT, initial <sup>3</sup>				100		pA
BIAS CURRENT vs. supply				0.1		pA/V
OFFSET CURRENT, initial				50		pA
INPUT RESISTANCE, DC			100			G Ω
INPUT CAPACITANCE			4			pF
COMMON MODE VOLTAGE RANGE				+Vcc-20		V
COMMON MODE VOLTAGE RANGE				-Vcc+12		V
COMMON MODE REJECTION, DC		120	130			dB
NOISE	100kHz bandwidth, 1kΩ R <sub>s</sub>		1			μV RMS
<b>GAIN</b>						
OPEN LOOP	R <sub>L</sub> = 10kΩ, C <sub>c</sub> =10pF	108				dB
GAIN BANDWIDTH PRODUCT @ 1MHz	C <sub>c</sub> =10pF		1			MHz
PHASE MARGIN	Full temperature range	60				degree
<b>OUTPUT</b>						
VOLTAGE SWING	I <sub>o</sub> = 0.1A	+Vs-16	+Vs-12			V
VOLTAGE SWING	I <sub>o</sub> = -0.1A	-Vs+16	-Vs+12			V
CURRENT, continuous, DC				100		mA
CURRENT, pulse, ≤10mS, within SOA				200		mA
SLEW RATE, A <sub>v</sub> = -100	C <sub>c</sub> = 10pF		10			V/μS
SETTLING TIME, to 0.1%	2V Step, C <sub>c</sub> = 10pF		4			μS
RESISTANCE	No load, DC		32			Ω
<b>POWER SUPPLY</b>						
VOLTAGE		± 50	± 450	± 520		V
CURRENT, quiescent			0.800	1.2		mA
<b>THERMAL</b>						
RESISTANCE, AC, junction to air or case <sup>6</sup>	Full temperature range, f ≥ 60Hz			10 to air	9 to case	°C/W
RESISTANCE, DC junction to air or case	Full temperature range			12.5 to air	10 to case	°C/W
TEMPERATURE RANGE, substrate		-40		85	85	°C
TEMPERATURE RANGE, ambient <sup>5</sup>		-40		70	NA	°C

### NOTES:

1. Unless otherwise noted: T<sub>c</sub> = 25°C, compensation C<sub>c</sub> = 150pF, DC input specifications are ± value given, power supply voltage is typical rating.
2. Derate internal power dissipation to achieve high MTBF.
3. Doubles for every 10°C of case temperature increase.
4. +HV and -HV denote the positive and negative supply voltages to the output stage. +Vcc and -Vcc denote the positive and negative supply voltages to the small signal stages. +Vcc and -Vcc may not be more than + and - 20V greater than +Vs and -Vs respectively.
6. Rating applies if the output current alternates between both output transistors at a rate faster than 60Hz.
7. Power supply voltages +Vcc and -Vcc must not be less than +HV and -HV respectively. Total voltage +Vcc to -Vcc 1040V maximum.
9. Specifications for the PAD195-1 are the same as for the PAD195 except as shown in this column.

## SAFETY FIRST

The operating voltages of the PAD195 are potentially deadly. When developing an application circuit it is wise to begin with power supply voltages as low as possible while checking for circuit functionality. Increase supply voltages slowly as confidence in the application circuit increases. Always use a “hands-off” method whereby test equipment probes are attached or handled only when power is off.

## MOUNTING THE PAD195 AMPLIFIER

The amplifier is supplied with four 4-40 M/F hex spacers at the four corners of the amplifier. Once the amplifier is seated, secure the module with the provided 4-40 nuts and torque to 4.7 in lb [53 N cm] max. See “**Dimensional Information**” for a detailed drawing. It is recommended that the heat sink be grounded to the system ground. This can easily be done by providing a grounded circuit board pad around any of the holes for the mounting studs.

## MOUNTING THE PAD195-1 AMPLIFIER

In most applications the amplifier must be attached to a heat sink. Spread a thin and even coat of heat sink grease across the back of the PAD195-1 and also the heat sink where the amplifier is to be mounted. Push the amplifier into the heat sink grease on the heat sink while slightly twisting the amplifier back and forth a few times to bed the amplifier into the heat sink grease. On the final twist align the mounting holes of the amplifier with the mounting holes in the heat sink and finish the mounting using 4-40 hex male-female spacers and torque to 4.7 in oz [3.8 N cm] max. Mount the amplifier to the mother board with 4-40 X 1/4” screws. See Dimensional Information for additional recommendations.

## PHASE COMPENSATION

The PAD195 **must** be phase compensated. The compensation capacitor,  $C_C$ , is connected between pins 2 and 3. The compensation capacitor must be an NPO type capacitor rated for the full supply voltage (1000V). On page 2, under Amplifier Pinout and Connections, you will find a table that gives recommended compensation capacitance value for various circuit gains and the resulting slew rate for each capacitor value. Consult also the small signal response and phase response plots for the selected compensation value in the Typical Performance Graphs section. A compensation capacitor less than 10pF is not recommended.

## EXTERNAL CIRCUIT COMPONENTS

The output of the PAD195 can swing up to 1000V and this may stress or destroy external components that are often not seriously considered when developing circuits with small signal op amps. For example, it is often overlooked that the usual voltage rating for metal film resistors is only 200V and that application circuits using the PAD195 may place up to

1000V across the feedback resistor. High voltage rated resistors may be purchased for the feedback circuit or, alternately, several ordinary resistors may be placed in series to obtain the proper voltage rating. We recommend at least five resistors in series for the feedback resistor. The compensation capacitor  $C_C$  is a NPO type and is rated for 1000V. The voltage rating of the connecting wire and PCB spacing between pads and connecting traces needs to be considered as well. See application note AN-16 for details.

## CURRENT LIMIT

Current limit can be programmed by attaching a suitable value resistor as shown in Figure 1. The value of the limited current can be approximately calculated by:

$$I_L = .65/R_S$$

Where  $I_L$  is the value of the limited current and  $R_S$  is the value of the current sense resistor. It is important that the type of resistor chosen for  $R_S$  be non-inductive. A wire-wound resistor is not a good choice even if it rated as “non-inductive” since it will exhibit significant inductance at some frequency. A better choice is a type of resistor that is more inherently non-inductive such as a powdered metal resistor or a thick film resistor. The power dissipation rating of the sense resistor should not be forgotten. The current limit circuitry works by diverting the stage currents of the amplifier into the output circuit (about 0.3mA) and this introduces an error term compared to the approximate equation given above. As the current limit value is reduced the proportion of the error term increases. The practical range of current limit is from 200mA to 2mA. The current limit decreases 2.2mV/°C with increasing temperature since the sense voltage for calculating the current limit is the emitter-base circuit of a bipolar transistor.

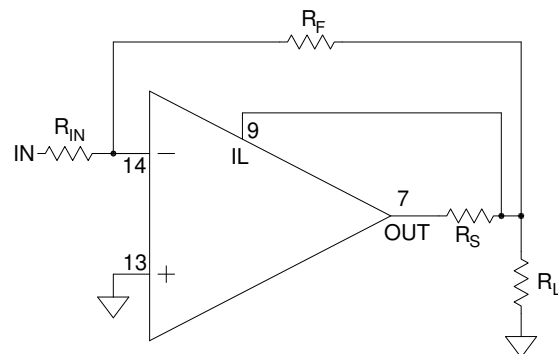
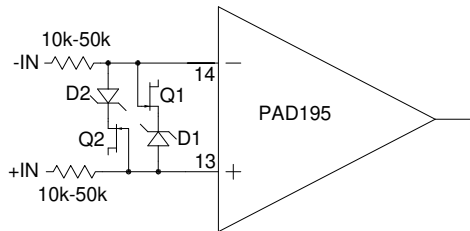

Figure 1  
Current Limit

OPERATING CONSIDERATIONS CONTINUED

**INPUT PROTECTION**

In applications where the input differential voltage may be exceeded (dc or transient) it is important to add differential input voltage protection. See Figure 2.



Q1=Q2 2N4416 OR SIMILAR  
D1=D2 BZX84C12TA OR SIMILAR (12V, 350mW)

Figure 2  
Input differential voltage protection

It is important that the power supply connections to the PAD195 not be open. If for example, the negative supply connection were to open, the internal circuitry of the amplifier will bootstrap the amplifier to the positive supply through the feedback gain-setting resistor. When the +IN is grounded the input circuit is clamped to ground while the output of the amplifier will float to the positive supply voltage via the bootstrapping effect. The input differential voltage of the amplifier may be exceeded destroying the input stage. This is one good reason to protect the input as shown in Figure 2. But it is also a good reason to clamp the power supply pins as shown in Figure 3 below.

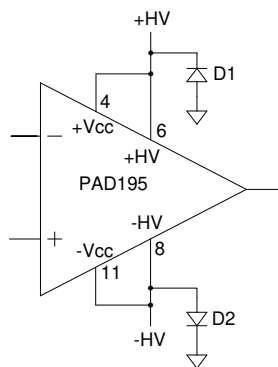

D1=D2 STTH812D OR SIMILAR (1200V)

Figure 3  
Power supply clamps

**CONFORMAL COATING**

The circuit of the PAD195 is covered by a silicone conformal coating for extra protection against internal arcing and environmental considerations such as humidity. The conformal coating is soft and may be damaged by rough handling. It is

therefore recommended that the circuit be handled only by the edges of the substrate to avoid disturbing the coating. The PAD195 is only rated for normal environmental conditions of atmospheric pressure, humidity and temperature usually found in a laboratory or production floor. The user must make appropriate steps to insure the reliability of the application circuit beyond those conditions.

**Power Amp Design ♦ PAD195 ♦ COMPACT HIGH VOLTAGE OP AMP**

TBA

*PowerAmp Design* ♦ PAD195 ♦ COMPACT HIGH VOLTAGE OP AMP

TBA

*PowerAmp Design* ♦ PAD195 ♦ COMPACT HIGH VOLTAGE OP AMP

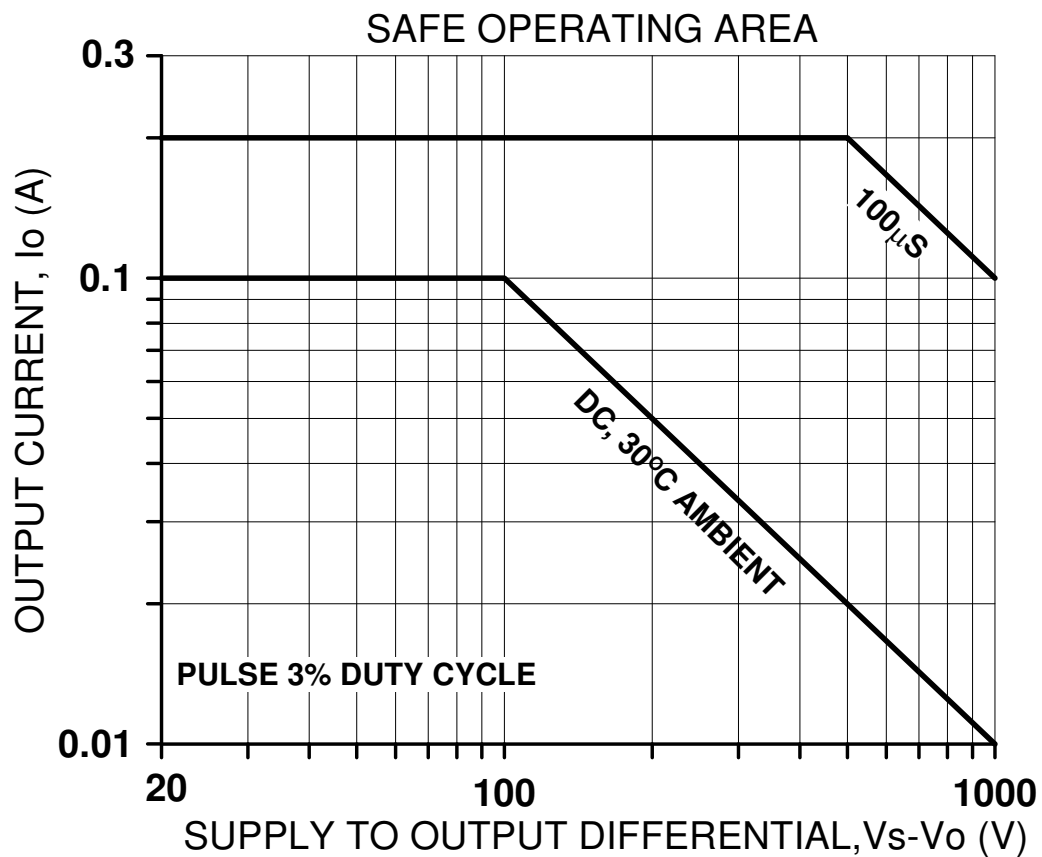

**SAFE OPERATING AREA**

**PowerAmp Design ♦ PAD195 ♦ COMPACT HIGH VOLTAGE OP AMP**



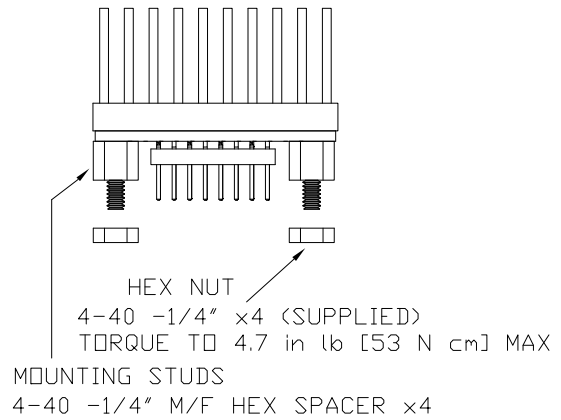
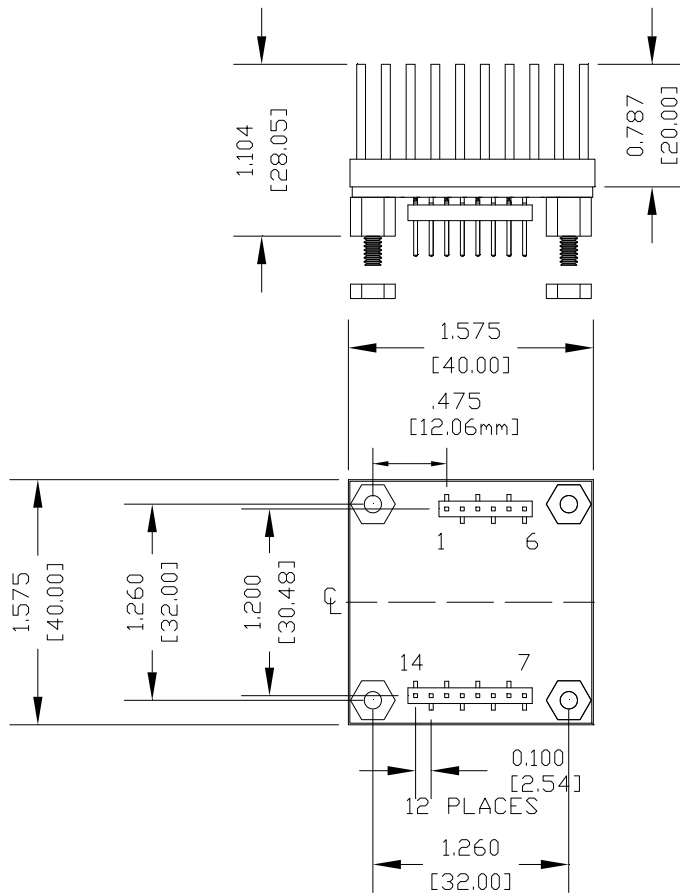

- NOTES:
1. PINS .025" SQUARE X22
  2. RECOMMENDED HOLE FOR MOUNTING 0.129" X4
  3. RECOMMENDED HOLE FOR PINS 0.052" D.
  4. TOTAL ASSEMBLY WEIGHT APPROX 1.63oz [46.1 g]
  5. HEAT SINK WEIGHT APPROX 0.96 oz [27.2 g]

**PowerAmp Design ♦ PAD195 ♦ COMPACT HIGH VOLTAGE OP AMP**

DIMENSIONAL INFORMATION CONTINUED

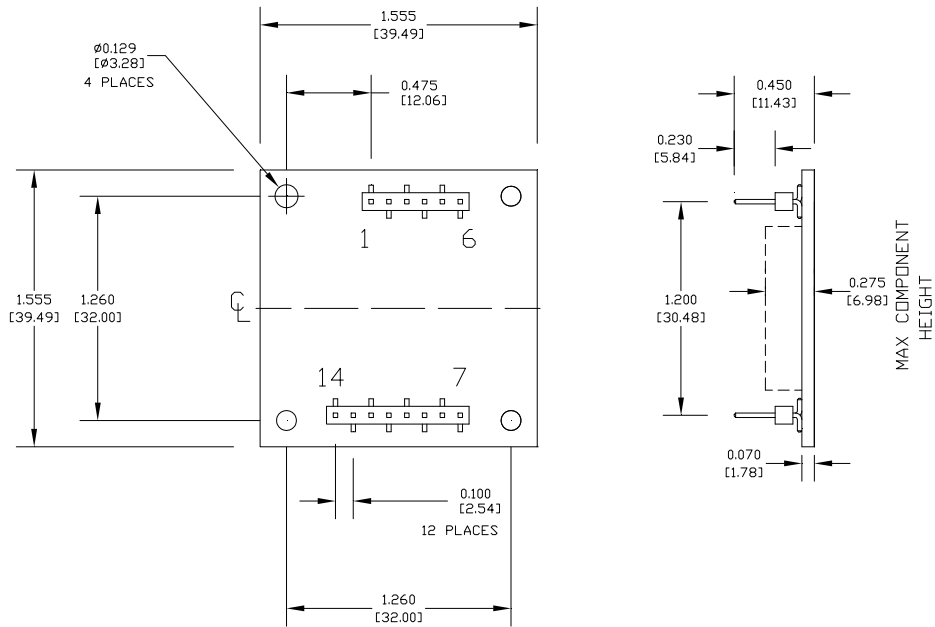

- NOTES: 1: DIMENSIONS ARE INCHES, [mm]  
 2: PINS 0.025" SQUARE [0.635mm], GOLD PLATED  
 3: RECOMMENDED HOLE FOR MOUNTING 0.129" D. x2 [3.277mm]  
 4: RECOMMENDED HOLE FOR PINS 0.052" D. [1.321mm]  
 5: HIGHLY RECOMMENDED THAT AMPLIFIER IS MOUNTED INTO CAGE JACKS USING PAD PART NUMBER CJS01. USE 0.062" [1.575mm] HOLE FOR CAGE JACKS.  
 6: HIGHLY RECOMMENDED THAT AMPLIFIER IS MOUNTED INTO HEAT SINK WITH 4-40 M/F SPACERS TO PROVIDE STRAIN RELIEF FOR PINS. SEE DRAWING BELOW.

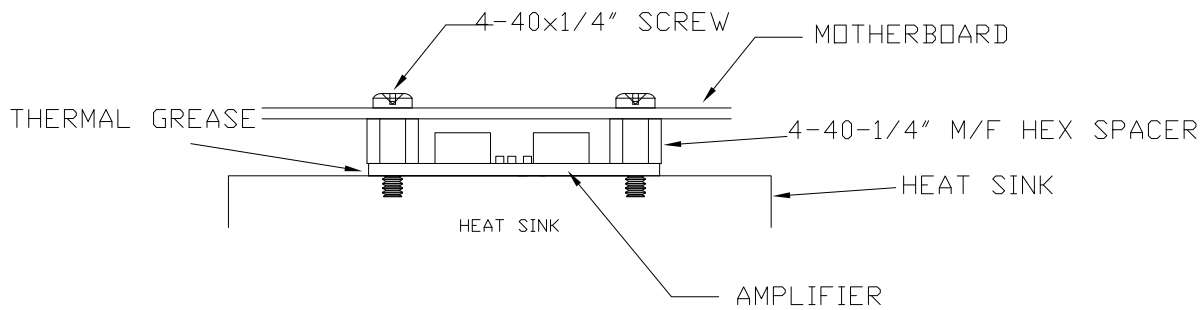

PAD195-1

**PowerAmp Design ♦ PAD195 ♦ COMPACT HIGH VOLTAGE OP AMP**

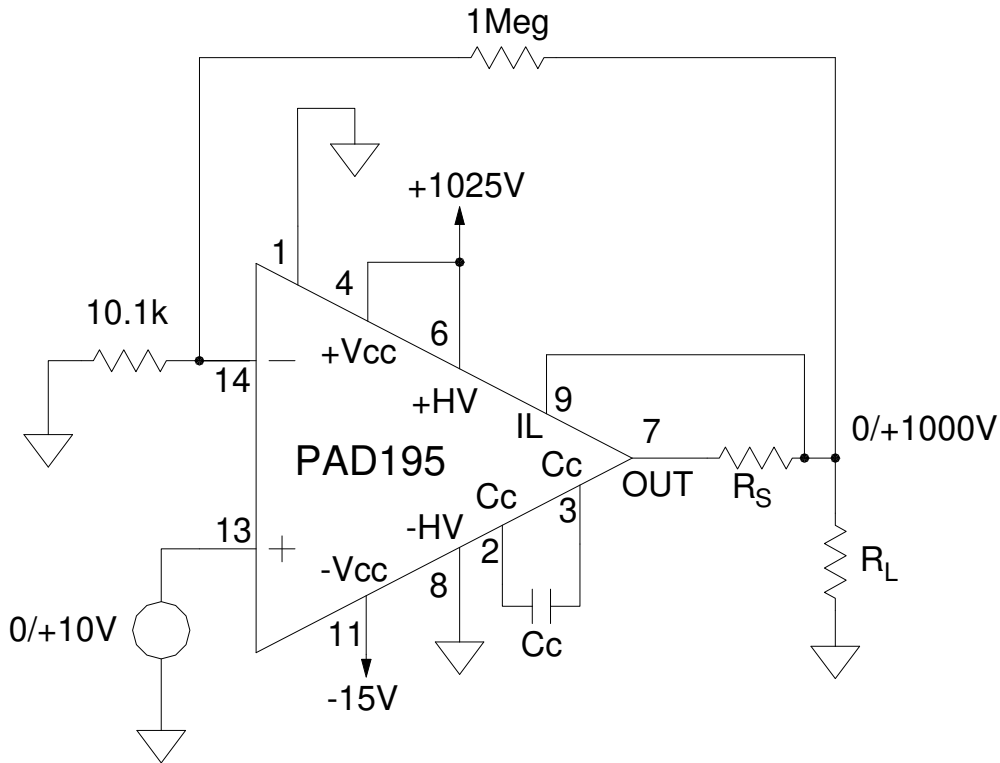

FIGURE 3  
 APPLICATION CIRCUIT  
 1000V PROGRAMMABLE VOLTAGE SOURCE

**Power Amp Design ♦ PAD195 ♦ COMPACT HIGH VOLTAGE OP AMP**